



aerospace
 climate control
 electromechanical
filtration
 fluid & gas handling
 hydraulics
 pneumatics
 process control
 sealing & shielding



OIL-X EVOLUTION

High Efficiency Compressed Air Filters

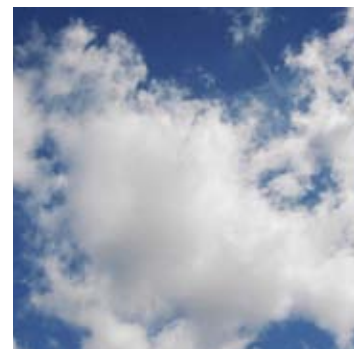

ENGINEERING YOUR SUCCESS.

Compressed air contamination is a real problem for industry

In today's modern production facilities, the use of compressed air is often pivotal to manufacturing processes. Irrespective of whether the compressed air comes into direct contact with the product or is used to automate a process, provide motive power, or even to generate other gases on-site, a clean, dry, reliable compressed air supply is essential to maintain efficient and cost effective production.

Most problems experienced by compressed air users derive from contamination already in the compressed air system. Typically there are 10 different contaminants from four different sources and even more in critical applications. that need to be removed or reduced to acceptable levels.



Atmospheric dirt



Water vapour



Oil vapour

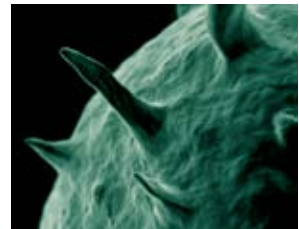

Micro-organisms

Failure to remove or reduce contamination will cause many problems with the compressed air system, for example:

- Corrosion within compressed air storage vessels and the air distribution system
- Blocked or damaged valves, cylinders, air motors and air tools
- Damaged production equipment
- Premature and unplanned desiccant changes for adsorption dryers
- Product contamination

In addition to problems associated with the compressed air system itself, allowing contaminants such as particulate, oil and micro-organisms to exhaust from valves, cylinders and air tools, can lead to an unhealthy and unsafe working environment.

Compressed air contamination will ultimately lead to:

- Inefficient production processes
- Spoiled, damaged or reworked products
- Reduced production efficiency
- Increased manufacturing costs

Parker domnick hunter has a cost effective solution for every contaminant

Purification Equipment Technologies	Contamination Removal							
	Bulk Condensed Water	Water Vapour	Water Aerosols	Atmospheric Dirt & Solid Particulate	Micro-organisms	Oil Vapour	Liquid Oil & Oil Aerosols	Rust & Pipescale
Water Separators	•							
Coalescing Filters			•	•	•		•	•
Adsorption Filters						•		
Adsorption Dryers		•						
Refrigeration Dryers		•						
Dust Removal Filters				•	•			•
Microbiological Filters				•	•			

Many manufacturers offer compressed air filters, that look the same, claim the same, but are not the same.

Parker domnick hunter – Your Compressed Air Purification Partner

Parker domnick hunter - The original name in Compressed Air Purification



The origins of modern compressed air filtration can be traced back to domnick hunter in 1963, it was the first company to use microfibre filter media for purification applications, changing the compressed air industry forever.

The OIL-X filter range was the first filter range to fully utilise this groundbreaking technology and has always been synonymous with high quality compressed air. Now in the 21st century, the OIL-X name remains, but the technology has evolved beyond recognition.

Parker domnick hunter OIL-X EVOLUTION

Since the introduction of the first OIL-X range, Parker domnick hunter has continued to develop both the compressed air filter and the standards governing compressed air quality. Constantly innovated, OIL-X EVOLUTION has become the leading technology for compressed air filtration, providing the exact balance between air quality, energy efficiency and low lifetime costs.

- Industry leading design
- World-wide approvals for safety and reliability
- Meets or exceeds the requirements for delivered air quality shown in all editions of ISO8573-1, the international standard for compressed air quality
- Fully tested in accordance with ISO12500-1
- Performance independently validated by Lloyds Register
- The only filter range to offer a one year air quality guarantee
- 10 years guarantee on filter housings
- World-wide Parker support network
- OIL-X EVOLUTION - often copied, never matched

APPROVALS, ACCREDITATIONS AND ASSOCIATIONS



ISO9001:2000 ISO14001



INTERNATIONAL APPROVALS



The Parker domnick hunter Design Philosophy

Parker domnick hunter has been supplying industry with high efficiency filtration and purification products since 1963. Our philosophy 'Designed for Air Quality & Energy Efficiency' ensures products that not only provide the user with clean, high quality compressed air, but also with low lifetime costs and reduced CO₂ emissions.



Air Quality

The primary reason for using a compressed air filter is to remove contamination and improve air quality.

Parker domnick hunter's design Philosophy of Air Quality & Energy Efficiency has led to a product that provides:

- **Highest air quality**
- **Lowest power consumption**
- **Lowest operational differential pressure**
- **Lowest CO₂ emissions**
- **Lowest total cost of ownership**

Air Quality Claims

Most compressed air filter manufacturers claim that the delivered air from their filters complies with the quality classifications of ISO8573 part 1 when tested with the methods and equipment stated in ISO8573 parts 2-9, but how do they really perform?

Parker domnick hunter – The ethical filter company

In a comparative test of OIL-X EVOLUTION against five commonly available alternative filters, OIL-X EVOLUTION is the only filter range to meet or exceed literature claims for oil carryover and differential pressure for all grades.

	General Purpose Grade			High Efficiency Grade		
	Meets Literature Claims			Meets Literature Claims		
	Oil Carry Over	Initial Dry dP	Initial Wet dP	Oil Carry Over	Initial Dry dP	Initial Wet dP
OIL-X EVOLUTION	Green	Green	Green	Green	Green	Green
Sample 1	Yellow	Red	Red	Yellow	Red	Red
Sample 2	Red	Orange	Orange	Red	Orange	Orange
Sample 3	Red	Red	Yellow	Yellow	Yellow	Yellow
Sample 4	Red	Red	Orange	Red	Red	Orange
Sample 5	Red	Red	Yellow	Green	Red	Yellow

KEY	Meets Literature Claims
	Does Not Meet Literature Claims
	Data Not Published - Performance Worse Than OIL-X EVOLUTION
	Meets Literature Claims - Performance Worse Than OIL-X EVOLUTION
	Meets Literature Claims - Performance Better Than OIL-X EVOLUTION

Filters tested Pdh General Purpose & High efficiency Grades against nearest equivalents. Test method used: ISO12500-1. Results independently verified by Lloyds Register.

OIL-X EVOLUTION – The filter range you can trust

- **Air quality which meets or exceeds the requirements of ISO8573-1 (all revisions)**
- **Performance tested in accordance with ISO12500 & ISO8573**
- **Only filter range to offer a one year air quality guarantee**
- **Filtration performance independently verified by Lloyds Register**



Energy Efficiency

Any restriction to air flow within a filter housing and element will reduce the system pressure. To generate compressed air, large amounts of electrical energy are consumed, therefore any pressure losses within the system can be directly converted into a cost for wasted energy. The higher the pressure loss, the higher the energy cost.

When comparing the running cost of alternative filters, many will calculate the energy cost of the filter, using the differential pressure or dP values printed in literature. As demonstrated, these figures are not always accurate. Additionally, literature values are only representative of the

filter in an “as new” condition, and do not take into consideration the initial and on-going blockage characteristics of the filter. Although filters and elements may look the same, their blockage characteristics and operational costs are quite different

Differential Pressure – An accurate picture

In a comparative test of OIL-X EVOLUTION filters against five commonly available alternative filters, the blockage characteristics and therefore the true differential pressure of each filter can be demonstrated.

Operational dP

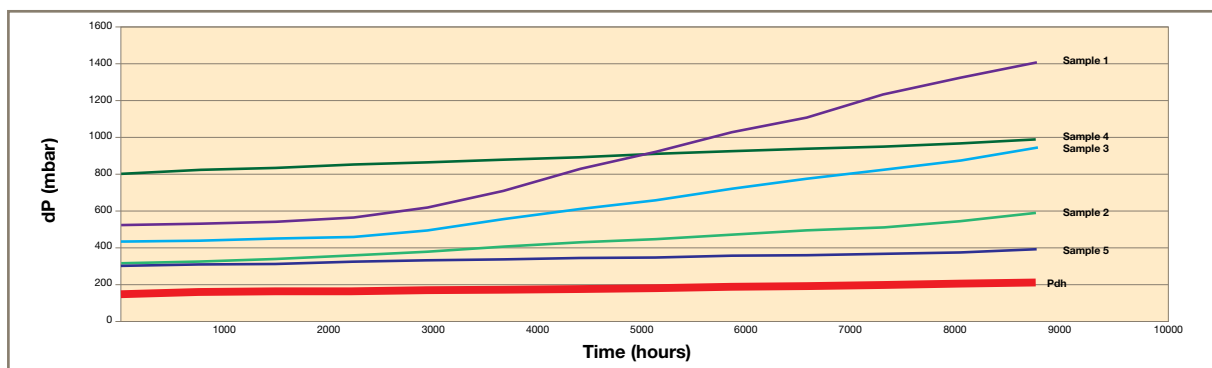

Test criteria: Filters were tested at their full rated flow and injected with ISO 12103 A4 course test dust using a pressurised dust injection system. The dust was injected in 12 intervals to simulate the monthly loading of the filter element and show a total annual differential pressure curve. OIL-X EVOLUTION filters were tested at an identical flow rate to the comparative filter and with an identical dirt loading.

The accurate running costs of a filter

Using the above data, a true picture of energy consumption can be seen.

Comparison of annual energy usage (4000 hrs operation)

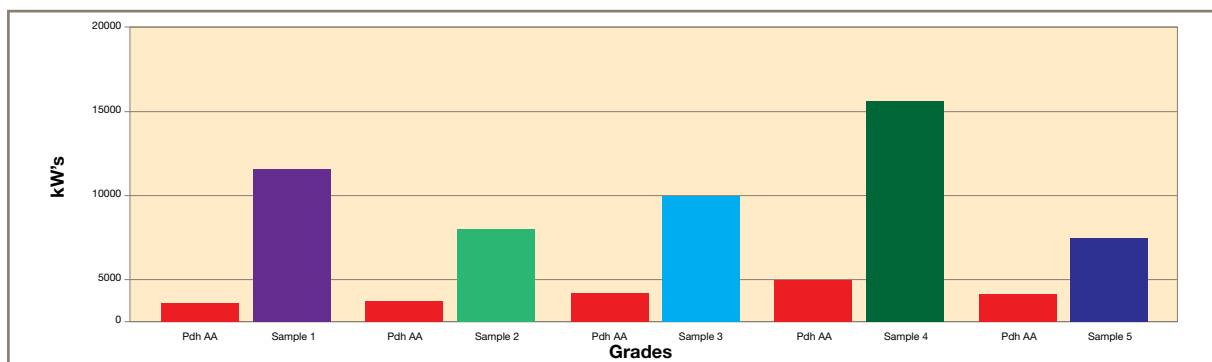

This calculation based upon a 75kW compressor operating for 4000 hours

OIL-X EVOLUTION – Payback within first year!

OIL-X EVOLUTION

The most energy efficient compressed air filters in the world.



Low Lifetime Cost

A filter with a low purchase price may not always turn out to be the most cost effective solution

Five years total cost of ownership

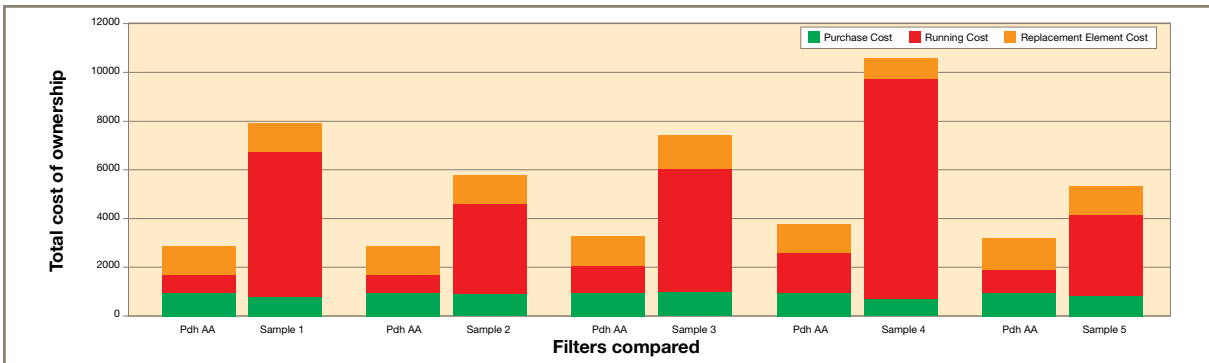

Calculation based upon initial purchase price of the filter housing, cost of £0.10 per kWh and five annual filter element changes. An estimated annual increase of 3% was included on both energy costs and element price.

And remember, not all filters achieved their claimed air quality!



Reduced CO₂ Emissions

Many countries worldwide are looking closely at their manufacturing industries in an effort to reduce the amount of harmful greenhouse gases released into the atmosphere. The use of electricity has a direct impact on

the generation and release of CO₂. By significantly reducing the energy consumption of its products, Parker can help you to reduce your carbon footprint and protect the environment.

Comparison of annual CO₂ emissions (4000 hrs Operation)

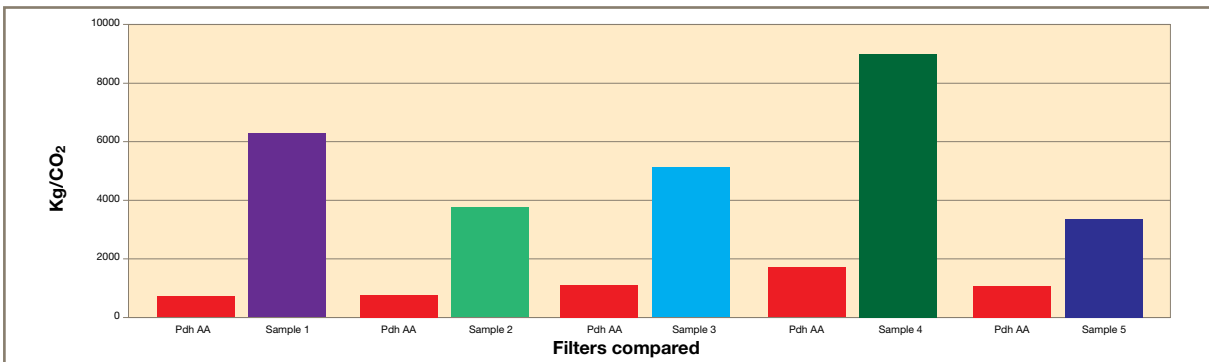

Calculation assumes 1kWh emits 0.544Kg/CO₂ (Information provided by UK Carbon Trust at time of publication)

OIL-X EVOLUTION - The environmentally friendly filter

OIL-X EVOLUTION

Water Separators - Grade WS

- The world's most energy efficient Water Separators
- For the removal of bulk condensed water and liquid oil
- Used to protect coalescing filters from bulk liquid contamination
- High liquid removal efficiencies at all flow conditions
- Tested in accordance with ISO8573-9



How OIL-X EVOLUTION Water Separators work

Parker domnick hunter OIL-X EVOLUTION WS Water Separators utilise centrifugal technology which provides a more efficient method of bulk liquid removal. Using a combination of direction change and centrifugal action, water is effectively separated from the compressed air flow. Parker domnick hunter centrifugal separators are very efficient with varying flow conditions and have been further optimised to reduce energy costs.

- Wet air enters the inlet port and is directed into the separator module fixed turning vanes causing the air to spin inside the vessel and then change direction as it passes the impinger.
- A vortex is then created which narrows and intensifies as it reaches the lower part of the separator.
- Bulk liquid is therefore removed from the air stream due to a combination of:
 - Directional changes of the air stream.
 - Velocity changes.
 - Centrifugal action of the vortex.
- As the vortex reaches the bottom of the separator module, air is forced through the centre of the vortex.
- Aerospace turning vanes located in the outlet of the separator module now turn an "inefficient corner" into a number of more "efficient corners" to reduce turbulence, minimise pressure loss and therefore operational costs.

In addition to protecting coalescing filters from bulk liquid contamination, Grade WS Water Separators can be used on compressor inter-cooler and after-cooler stages, wet air receivers and refrigeration dryers.

OIL-X EVOLUTION

High efficiency coalescing and dust removal filters

- For the removal of water and oil aerosols, atmospheric dirt and solid particles, rust, pipescale and micro-organisms
- Coalescing filter performance tested to the stringent requirements of ISO12500-1 and ISO8573-2
- Dry particulate filter performance tested in accordance with the requirements of ISO8573-4



OIL-X EVOLUTION – Features that provide air quality

The Parker domnick hunter OIL-X EVOLUTION range of die-cast compressed air filters has been designed from the outset to meet the air quality requirements of all editions of ISO8573-1, when validated in accordance with the stringent requirements of ISO12500-1.

Correct selection of filtration media

Coalescing and dust removal filters use a high efficiency borosilicate glass nanofibre material which has a 96% voids volume, providing media with excellent filtration efficiency and a high dirt holding capacity.



Construction of the filtration media into a filter element

OIL-X EVOLUTION filter media is constructed into a filter element using a unique deep bed pleating technique in place of the more conventional wrapped construction. This provides 450% more filtration surface area when compared to a traditional wrapped filter element and around 200% more surface area compared to a traditional pleated element. Deep bed pleating also reduces the air flow velocity within the media, which further improves filtration performance.

Additionally, the high efficiency AA and AAR grade elements have a unique graded density media construction which provides even greater filtration performance without adding to pressure loss or energy consumption.



OIL-X EVOLUTION

coalescing filters utilise four drainage methods to ensure high performance liquid removal, whilst conventional filters use only one.

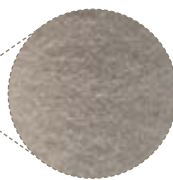

Drainage method 1

High efficiency drainage layer provides increased liquid drainage, improved chemical compatibility and higher operational temperatures when compared to ordinary materials.

Typical element



Wet band in air flow path

OIL-X EVOLUTION



No wet band in air flow path

Drainage method 2

Typical filter elements have a build up of liquid known as a "wet band" where the drainage layer is glued into the lower endcap. The OIL-X EVOLUTION design wraps the drainage layer under the lower endcap to remove coalesced liquid from the air flow path, increasing liquid removal efficiency, and providing more usable filtration surface area.



Drainage method 3

Surface tension breakers on the lower filter element endcap provide fast and efficient drainage of coalesced liquid.

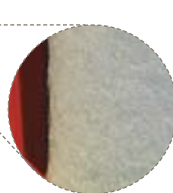

Drainage method 4

Drainage ribs cast into the filter bowl compress the lower part of the filter element, allowing bulk liquid to rapidly drain from the filter element through capillary action.

OIL-X EVOLUTION – Features providing energy efficiency

In these times of increasing energy costs, an efficient and cost effective manufacturing process is a major factor in maintaining the profitability and growth of your business. All Parker domnick hunter products are designed to not only minimise the use of compressed air and electrical energy in their operation, but also to significantly reduce the operational costs of the compressor by minimising pressure losses.

OIL-X EVOLUTION filters incorporate a number of unique and patented design features to minimise differential pressure and provide a filter and element combination where the differential pressure starts low and stays low to maximise energy savings and provide the lowest lifetime costs without compromising air quality.

OIL-X EVOLUTION die-cast filters optimised flow path from patented Aerospace Flow Management System

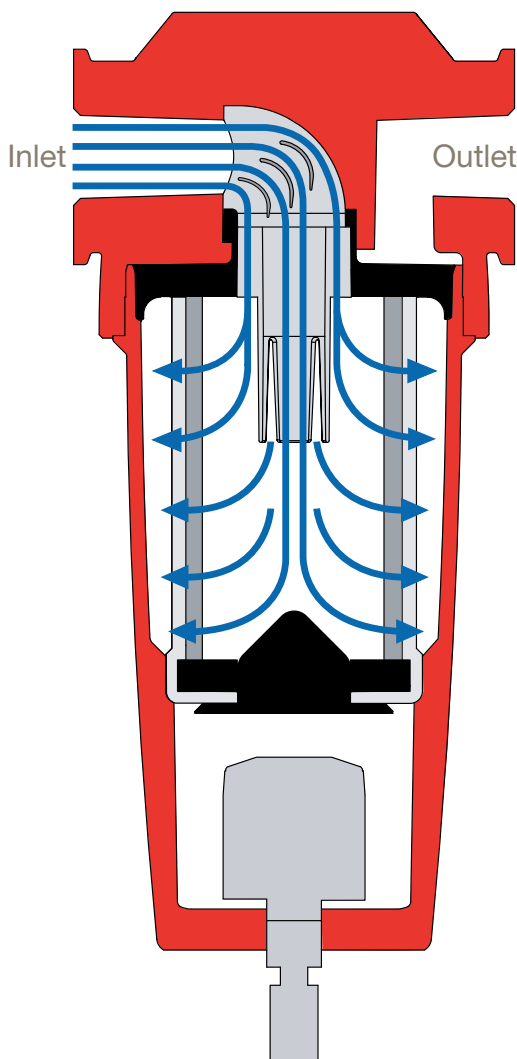

Providing an optimal flow path for the compressed air through the filter housing and element is key to reducing system operating costs

Pressure losses in a compressed air filter is a combination of fixed pressure losses and incremental pressure losses. Fixed pressure losses are derived from the filter housing and the interface between the filter housing and filter element.

Incremental pressure losses are directly related to the filter element as it blocks up with contamination.

In most filters, high operational costs can be attributed to an inefficient air flow path within the filter housing and element and poorly selected filtration media.

In addition to this, the high differential pressure “change points” recommended by many filter manufacturers increase operational costs even further.



“Bell mouth” housing inlet & full flow inlet conduit



Smooth 90° elbow & aerospace turning vanes



Flow distributor



Conical flow diffuser



Deep bed pleating

Deep bed pleating reduces the air flow velocity within the filtration media. This both improves filtration performance of the filter element and also reduces pressure losses.



Specialist media treatment

All OIL-X EVOLUTION coalescing and dust removal filter media includes a specialist treatment. This actively repels oil and water to ensure that coalesced liquid does not reduce the voids volume. Maintaining a high voids volume reduces the risk of premature blockage, system pressure losses and high energy consumption.

Advanced filter housings

OIL-X EVOLUTION die-cast filter housings provide simple installation and long housing life with reduced maintenance. The unique design of the OIL-X EVOLUTION die-cast filter also provides more port sizes to give greater application flexibility. A 'clean change' element design ensures that service technicians do not have to directly handle contaminated filter elements during maintenance.



Filter connections

More port sizes are available to match both pipe size and system flow rate giving additional customer choice and reduced installation costs. Standard range suitable for pressures up to 20 bar g (290 psi g).



No corrosion with Alocrom treatment.

Rapid corrosion of untreated aluminium.

Compact and lightweight

Advanced element design provides a smaller, more compact filter.

Full corrosion protection

OIL-X EVOLUTION filter housings undergo cleaning, de-greasing and Alocrom treatment before painting. This not only primes the aluminium surface for painting, but also provides corrosion protection. All OIL-X EVOLUTION filter housings are protected with a tough, durable dry powder epoxy coating.



'Clean change' filter element

Filter element changes are now easy and do not require the user to directly handle the contaminated element during annual maintenance.

Minimal service clearance

Space saving design minimises service clearance and allows installation in confined spaces.



Float drain

Choice of drains

Grade AO and AA coalescing filters are fitted with energy efficient, zero air loss float drains as standard for the removal of coalesced liquids. Grade AR and AAR dust removal filters and grade ACS adsorption filters are fitted with manual drains.

OIL-X EVOLUTION for larger flowrates

4" Die-Cast Aluminium and Carbon Steel Fabricated Filters.

For larger flowrate applications, Parker domnick hunter manufactures cast aluminium 4" ported filters and a range of fabricated carbon steel filters from DN50 to DN300 sized flanges. These filters are also available in the standard five filtration grades.



4" Die-cast aluminium filters

- Cost effective alternative to flanged, fabricated carbon steel vessels
- Standard range up to 20 bar g (290 psi g)
- Alocrom and dry powder epoxy coated for full corrosion protection
- NT Easy fit element location for quick and simple maintenance



Carbon steel fabricated filters

- Fabricated from carbon steel
- Standard range up to 16 bar g (232 psi g)
- Stainless steel models also available
- Designed to ASME VIII Div 1 (non-U)
- Specialist housings also available
- NT Easy fit element location for quick and simple maintenance
- Higher pressures available
- Filters for other gases available

NT Easy fit element technology

- Low pressure drop when compared to traditional wrapped filter elements
- Drainage layer is suitable for use up to 100°C and is compatible with all compressor oils



Special endcap design allows for quick and easy maintenance.



No tie-rod to reduce pressure drop and simplify installation.



Pleated element technology for increased filtration area



Lower endcap design eases installation and prevents damage to drainage layer.

High capacity drainage layer ensures that all coalesced liquids are removed.

OIL-X EVOLUTION - OVR Oil Vapour Removal

Oil vapour is oil in a gaseous form and will pass straight through coalescing filters which are designed to remove liquid oil and oil aerosols.

Parker domnick hunter use adsorption filter technology for the removal of oil vapours. The OIL-X EVOLUTION range consists of three types of oil vapour removal filters, modular carbon towers - Grade OVR, single stage in-line filters - Grade ACS and double stage in-line filters - Grade AC which consist of both coalescing and adsorption filter elements combined into one unit.

Oil vapour removal filters are selected based upon their position in the system and the frequency with which the elements can be changed.

OIL-X EVOLUTION Grade OVR can be used for both plant scale protection and at the point of use. OIL-X EVOLUTION Grade OVR filters are also used when frequent element changes cannot be tolerated by the user.

OIL-X EVOLUTION Grades ACS and AC are used for smaller flow rate applications, point of use applications and applications where more frequent element changes can be tolerated.



Grade OVR



Grade ACS



Grade AC

OIL-X EVOLUTION adsorption filters utilise two types of adsorbent:

- **OIL-X EVOLUTION - Grade OVR uses activated carbon granules**
- **OIL-X EVOLUTION - Grade ACS uses 100% activated carbon cloth**
- **OIL-X EVOLUTION - Grade AC use a combination of both adsorbents (depending upon flow rate)**



Carbon granules



100% activated carbon cloth

Removing oil vapour from compressed air is necessary to meet the air quality standards required by many critical applications and processes within industries such as pharmaceutical, medical, chemical, electronics, food and beverage and breathing air applications.

Maintaining Air Quality

Annual filter element changes are essential (coalescing and dust removal filters)



To maintain your guaranteed air quality, filter elements must be replaced every year with genuine Parker domnick hunter parts.

Throughout its' life, the filter element is constantly under bombardment from oily, acidic condensate and high velocity dirt particles, which it has to remove and retain to protect your compressed air system. Over time, this can weaken the filter media and reduce filtration performance. This potential but critical reduction in filtration performance cannot be detected by simple differential pressure monitoring techniques.

Annual filter element changes are therefore essential and failure to replace every year could result in reduced production performance, degrading air quality and increased operational costs.

Annual filter element changes ensure:

- **Optimal performance is maintained**
- **Air quality continues to meets international standards**
- **Protection of downstream equipment, personnel and processes**
- **Low operational costs**
- **Increased productivity and profitability**
- **Peace of mind**

Maintenance of oil vapour removal filters



Unlike oil aerosol removal filters which are changed annually to guarantee compressed air quality, the lifetime of an oil vapour removal filter can be attributed to various factors and require more frequent changes (unless OVR is used which is sized for 6000hrs life):

Factors affecting the lifetime of adsorption filters

Oil vapour concentration

The higher the inlet concentration of oil vapour, the faster the activated carbon capacity will expire.

Bulk oil

Adsorption filters are designed to remove oil vapour and odours, not liquid oil or aerosols. Poorly maintained or non-existent pre-filtration will cause the OVR filter capacity to quickly expire.

Temperature

Oil vapour content increases proportionally to inlet temperature, reducing element life. Additionally, as temperature increases, the adsorption capacity decreases, again reducing element life.

Relative Humidity or Dewpoint

Wet air reduces the adsorptive capacity of the carbon - always try to install an adsorption filter after a dryer.

Compressor oil changes

When compressor oil is changed, the new lubricant burns off "light ends" which increases the oil vapour content for hours or even weeks afterwards. This increase in oil vapour content is adsorbed by the OVR filter, significantly reducing its adsorptive life.

OIL-X EVOLUTION

Water Separators - Grade WS

Separation Performance (models WS010 - WS055)

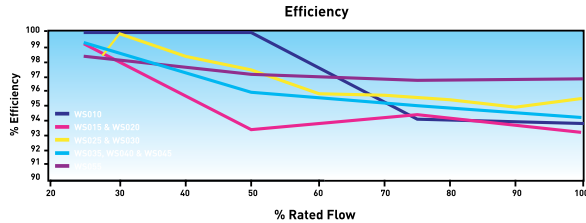

Differential Pressure versus Flow (models WS010 - WS055)

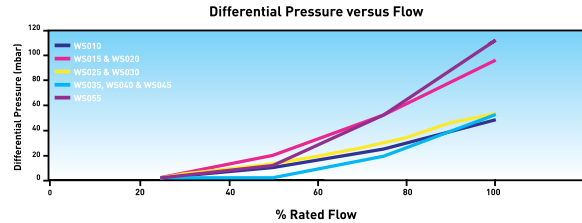

Product Selection

Stated flows are for operation at 7 bar g (100 psi g) with reference to 20°C, 1 bar a, 0% relative water vapour pressure.

	Model	Pipe Size	L/S	m ³ /min	m ³ /hr	cfm
Cast Aluminium Range	WS010A <input type="checkbox"/> FX	1/4"	10	0.6	36	21
	WS010B <input type="checkbox"/> FX	3/8"	10	0.6	36	21
	WS010C <input type="checkbox"/> FX	1/2"	10	0.6	36	21
	WS015B <input type="checkbox"/> FX	3/8"	40	2.4	144	85
	WS020C <input type="checkbox"/> FX	1/2"	40	2.4	144	85
	WS020D <input type="checkbox"/> FX	3/4"	40	2.4	144	85
	WS020E <input type="checkbox"/> FX	1"	40	2.4	144	85
	WS025D <input type="checkbox"/> FX	3/4"	110	6.6	396	233
	WS030E <input type="checkbox"/> FX	1"	110	6.6	396	233
	WS030F <input type="checkbox"/> FX	1 1/4"	110	6.6	396	233
	WS030G <input type="checkbox"/> FX	1 1/2"	110	6.6	396	233
	WS035F <input type="checkbox"/> FX	1 1/4"	350	21	1260	742
	WS040G <input type="checkbox"/> FX	1 1/2"	350	21	1260	742
	WS045H <input type="checkbox"/> FX	2"	350	21	1260	742
	WS055I <input type="checkbox"/> FX	2 1/2"	800	48	2880	1695
WS055J <input type="checkbox"/> FX	3"	800	48	2880	1695	
Carbon Steel Range	WS1000	G 4	1000	60	3600	2119
	WS250F	DN40	350	21	1260	742
	WS800F	DN80	800	48	2880	1695
	WS1000F	DN100	1000	60	3600	2119
	WS1800F	DN150	1800	108	6480	3814
	WS3000F	DN200	3000	180	10800	6357
	WS4800F	DN250	4800	288	17280	10171
WS7200F	DN300	7200	421	25920	14885	

Correction Factors

Line Pressure		Correction Factor pressure (CFP)
bar g	psi g	
1	15	4.00
2	29	2.63
3	44	2.00
4	58	1.59
5	73	1.33
6	87	1.14
7	100	1.00
8	116	0.94
9	131	0.89
10	145	0.85
11	160	0.82
12	174	0.79
13	189	0.76
14	203	0.73
15	218	0.71
16	232	0.68
When ordering a WS filter for pressures above 16 bar g (232 psi g), use manual drain. Replace F with M in product code. e.g. 015BBFX becomes 015BBMX. Models 250F - 7200F not suitable for pressures above 16 bar g (232 psi g)		
17	248	0.67
18	263	0.65
19	277	0.63
20	290	0.62

To correctly select a filter model, the flow rate of the filter must be adjusted for the minimum operating pressure of the system.

- Obtain the minimum operating pressure and maximum compressed air flow rate at the inlet of the filter.
- Select the correction factor for minimum operating pressure from the CFP table (always round down e.g. for 5.3 bar, use 5 bar correction factor)
- Calculate the minimum filtration capacity
Minimum Filtration Capacity = Compressed Air Flow Rate x CFP
- Using the minimum filtration capacity, select a water separator model from the flow rate tables above (water separator selected must have a flow rate equal to or greater than the minimum filtration capacity)

Water separator coding example

WS010 - WS055

Grade	Model	Pipe Size	Connection Type	Drain Option	Incident Monitor Option
WS	3 digit code denotes filter housing size	Letter denotes pipe size	B = BSPT N = NPT G = BSPP DN = Flanged	F = Float M = Manual	X = None
Example code					
WS	010	A	B	F	X

Technical Data

Grade	Water Separator Models	Min Operating Pressure		Max Operating Pressure		Min Operating Temp		Max Operating Temp	
		bar g	psi g	bar g	psi g	°C	°F	°C	°F
WS	010A □ FX - 055J □ FX	1	15	16	232	2	35	80	176
WS	1000	1	15	16	232	2	35	66	150
WS	250F - 7200F	1	15	16	232	2	35	66	150

Weights and Dimensions

Model	Pipe Size	Height (H)		Width (W)		Depth (D)		Weight	
		mm	ins	mm	ins	mm	ins	kg	lbs
WS010A □ FX	1/4"	181	7.2	76	3.0	64	2.5	0.6	1.3
WS010B □ FX	3/8"	181	7.2	76	3.0	64	2.5	0.6	1.3
WS010C □ FX	1/2"	181	7.2	76	3.0	64	2.5	0.6	1.3
WS015B □ FX	3/8"	235	9.3	97	3.8	84	3.3	1.1	2.4
WS020C □ FX	1/2"	235	9.3	97	3.8	84	3.3	1.1	2.4
WS020D □ FX	3/4"	235	9.3	97	3.8	84	3.3	1.1	2.4
WS020E □ FX	1"	235	9.3	97	3.8	84	3.3	1.1	2.4
WS025D □ FX	3/4"	275	10.8	129	5.1	115	4.5	2.2	4.8
WS030E □ FX	1"	275	10.8	129	5.1	115	4.5	2.2	4.8
WS030F □ FX	1 1/4"	275	10.8	129	5.1	115	4.5	2.2	4.8
WS030G □ FX	1 1/2"	275	10.8	129	5.1	115	4.5	2.2	4.8
WS035F □ FX	1 1/4"	432	17	170	6.7	156	6.1	5.1	11.2
WS040G □ FX	1 1/2"	432	17	170	6.7	156	6.1	5.1	11.2
WS045H □ FX	2"	432	17	170	6.7	156	6.1	5.1	11.2
WS055I □ FX	2 1/2"	504	19.9	205	8.1	181	7.1	10.0	22.0
WS055J □ FX	3"	504	19.9	205	8.1	181	7.1	10.0	22.0
WS1000	G 4	847	33.3	420	16.5	282	11.1	42.0	92.0
WS250F	DN40	595	23.4	304	12.0	220	8.7	31	68
WS800F	DN80	1070	42.1	370	14.6	285	11.2	66	146
WS1000F	DN100	1120	44.1	450	17.7	340	13.4	102	225
WS1800F	DN150	1240	48.8	580	22.8	460	18.1	191	434
WS3000F	DN200	1585	62.4	750	29.5	640	25.2	397	875
WS4800F	DN250	1570	61.8	862	33.9	715	28.2	537	1184
WS7200F	DN300	1610	63.4	1000	39.4	840	33.1	675	1488

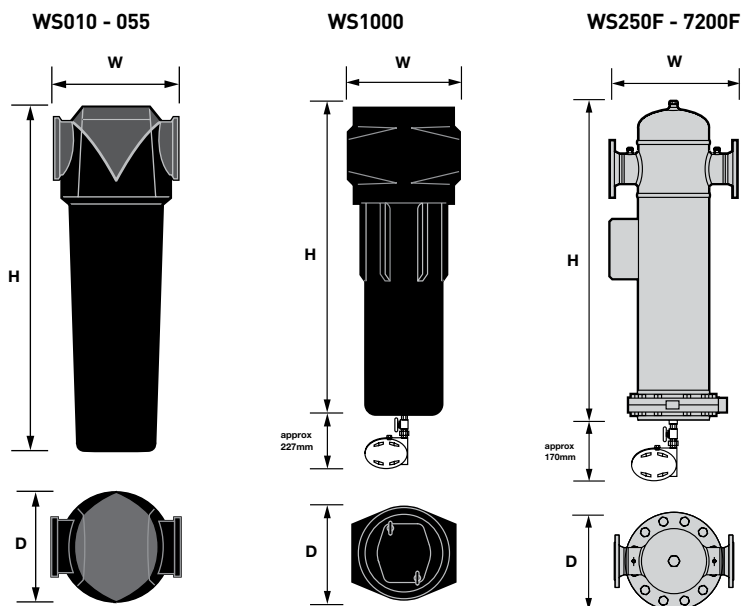

OIL-X EVOLUTION

Coalescing & Dry Particulate Filters – Grades AO/AA/AR/AAR

Filtration Grades

Filtration Grade	Filter Type	Particle removal (inc water & oil aerosols)	Max Remaining Oil Content at 21°C (70°F)	Filtration Efficiency	Initial Dry Differential Pressure	Initial Saturated Differential Pressure	Change Element Every	Precede with Filtration Grade
AO	Coalescing	Down to 1 micron	0.6 mg/m ³ 0.5 ppm(w)	99.925%	<70 mbar (1psi)	<140 mbar (2psi)	12 months	WS (for bulk liquid)
AA	Coalescing	Down to 0.01 micron	0.01 mg/m ³ 0.01 ppm(w)	99.9999%	<140 mbar (2psi)	<200 mbar (3psi)	12 months	AO
AR	Dry Particulate	Down to 1 micron	N/A	99.925%	<70 mbar (1psi)	N/A	12 months	N/A
AAR	Dry Particulate	Down to 0.01 micron	N/A	99.9999%	<140 mbar (2psi)	N/A	12 months	AR

Product Selection

Stated flows are for operation at 7 bar g (100 psi g) with reference to 20°C, 1 bar a, 0% relative water vapour pressure. For flows at other pressures apply the correction factors shown.

Correction Factors

	Model	Pipe Size	L/S	m ³ /min	m ³ /hr	cfm	Replacement Element kit	No.	Line Pressure		Correction Factor pressure (CFP)
									bar g	psi g	
Cast Aluminum Filters	grade 005A [] [] X	1/4"	6	0.4	22	13	005 grade	1	1	15	2.65
	grade 005B [] [] X	3/8"	6	0.4	22	13	005 grade	1	1.5	22	2.16
	grade 005C [] [] X	1/2"	6	0.4	22	13	005 grade	1	2	29	1.87
	grade 010A [] [] X	1/4"	10	0.6	36	21	010 grade	1	2.5	37	1.67
	grade 010B [] [] X	3/8"	10	0.6	36	21	010 grade	1	3	44	1.53
	grade 010C [] [] X	1/2"	10	0.6	36	21	010 grade	1	3.5	51	1.41
	grade 015B [] [] []	3/8"	20	1.2	72	42	015 grade	1	4	58	1.32
	grade 015C [] [] []	1/2"	20	1.2	72	42	015 grade	1	4.5	66	1.25
	grade 020C [] [] []	1/2"	30	1.8	108	64	020 grade	1	5	73	1.18
	grade 020D [] [] []	3/4"	30	1.8	108	64	020 grade	1	5.5	80	1.13
	grade 020E [] [] []	1"	30	1.8	108	64	020 grade	1	6	87	1.08
	grade 025D [] [] []	3/4"	60	3.6	216	127	025 grade	1	6.5	95	1.04
	grade 025E [] [] []	1"	60	3.6	216	127	025 grade	1	7	100	1.00
	grade 030E [] [] []	1"	110	6.6	396	233	030 grade	1	7.5	110	0.97
	grade 030F [] [] []	1 1/4"	110	6.6	396	233	030 grade	1	8	116	0.94
	grade 030G [] [] []	1 1/2"	110	6.6	396	233	030 grade	1	8.5	124	0.91
	grade 035F [] [] []	1 1/4"	160	9.6	576	339	035 grade	1	9	131	0.88
	grade 035G [] [] []	1 1/2"	160	9.6	576	339	035 grade	1	9.5	139	0.86
	grade 040G [] [] []	1 1/2"	220	13.2	792	466	040 grade	1	10	145	0.84
	grade 040H [] [] []	2"	220	13.2	792	466	040 grade	1	10.5	153	0.82
	grade 045H [] [] []	2"	330	19.8	1188	699	045 grade	1	11	160	0.80
	grade 050I [] [] []	2 1/2"	430	25.9	1548	911	050 grade	1	11.5	168	0.78
	grade 050J [] [] []	3"	430	25.9	1548	911	050 grade	1	12	174	0.76
	grade 055I [] [] []	2 1/2"	620	37.3	2232	1314	055 grade	1	12.5	183	0.75
grade 055J [] [] []	3"	620	37.3	2232	1314	055 grade	1	13	189	0.73	
grade 060K [] [] []	G 4	1000	60	3600	2119	060 grade	3	13.5	197	0.72	
grade 150ND [] [] []	DN80	430	25.9	1548	911	150 grade	1	14	203	0.71	
grade 200ND [] [] []	DN80	620	37.3	2232	1314	200 grade	1	14.5	212	0.69	
grade 250OD [] [] []	DN100	1000	60	3600	2119	060 grade	3	15	218	0.68	
grade 300OD [] [] []	DN100	1300	78	4680	2755	060 grade	4	15.5	226	0.67	
grade 350PD [] [] []	DN150	1950	117	7020	4132	060 grade	6	16	232	0.66	
grade 400QD [] [] []	DN200	3250	195	11700	6887	060 grade	10	When ordering an AO/AA filter for pressures above 16 bar g (232 psi g), use manual drain. Replace F with M in product code. e.g. 015BBFX becomes 015BBMX. Models 150 - 500 not suitable for pressures above 16 bar g (232 psi g)			
grade 450RD [] [] []	DN250	5200	313	18720	11019	060 grade	16				16.5
grade 500SD [] [] []	DN300	7800	469	28080	16528	060 grade	24	17	248	0.64	
									17.5	256	0.63
									18	263	0.62
									18.5	270	0.62
									19	277	0.61
									19.5	285	0.60
									20	290	0.59

Note: Connection sizes, (005 - 055) BSPT/NPT option available, G = BSPP and DN = flanged connection. To correctly select a filter model, the flow rate of the filter must be adjusted for the minimum operating pressure of the system

1. Obtain the minimum operating pressure and maximum compressed air flow rate at the inlet of the filter.
2. Select the correction factor for minimum operating pressure from the CFP table (always round down e.g. for 5.3 bar, use 5 bar correction factor)
3. Calculate the minimum filtration capacity
Minimum Filtration Capacity = Compressed Air Flow Rate x CFP
4. Using the minimum filtration capacity, select a filter model from the flow rate tables above (filter selected must have a flow rate equal to or greater than the minimum filtration capacity)

Technical Data

Filter Grade	Filter Models	Min Operating Pressure		Max Operating Pressure		Min Operating Temp		Max Operating Temp	
		bar g	psi g	bar g	psi g	°C	°F	°C	°F
AO/AA	005 □□ FX - 055 □□ FX	1	15	16	232	2	35	80	176
AO/AA	005 □□ MX - 055 □□ MX	1	15	20	290	2	35	100	212
AO/AA	060 K □ FX	1	15	16	232	2	35	66	150
AO/AA	060 K □ MX	1	15	20	290	2	35	100	212
AO/AA	150 NDFX - 500 SDFX	1	15	16	232	2	35	66	150
AO/AA	150 NDMX - 500 SDMX	1	15	16	232	2	35	100	212
AO/AA	005 □□ FI - 055 □□ FI	1	15	16	232	2	35	80	176
AO/AA	005 □□ MI - 055 □□ MI	1	15	20	290	2	35	100	212
AO/AA	060 K □ FI	1	15	16	232	2	35	66	150
AO/AA	060 K □ MI	1	15	20	290	2	35	66	150
AO/AA	150 NDFI - 500 SDFI	1	15	16	232	2	35	66	150
AO/AA	150 NDMI - 500 SDMI	1	15	16	232	2	35	66	150
AR/AAR	005 □□ MX - 055 □□ MX	1	15	20	290	2	35	100	212
AR/AAR	060 K □ MX	1	15	20	290	2	35	100	212
AR/AAR	150 NDMX - 500 SDMX	1	15	16	232	2	35	100	212
AR/AAR	005 □□ MI - 055 □□ MI	1	15	20	290	2	35	100	212
AR/AAR	060 K □ MI	1	15	20	290	2	35	66	150
AR/AAR	150 NDMI - 500 SDMI	1	15	16	232	2	35	66	150

Weights and Dimensions

Model	Pipe Size	Height (H)		Width (W)		Depth (D)		Weight	
		mm	ins	mm	ins	mm	ins	kg	lbs
005A	1/4"	154	6.1	76	3.0	64	2.5	0.5	1.1
005B	3/8"	154	6.1	76	3.0	64	2.5	0.5	1.1
005C	1/2"	154	6.1	76	3.0	64	2.5	0.5	1.1
010A	1/4"	181	7.2	76	3.0	64	2.5	0.6	1.3
010B	3/8"	181	7.2	76	3.0	64	2.5	0.6	1.3
010C	1/2"	181	7.2	76	3.0	64	2.5	0.6	1.3
015B	3/8"	235	9.3	97	3.8	84	3.3	1.1	2.4
015C	1/2"	235	9.3	97	3.8	84	3.3	1.1	2.4
020C	1/2"	235	9.3	97	3.8	84	3.3	1.1	2.4
020D	3/4"	235	9.3	97	3.8	84	3.3	1.1	2.4
020E	1"	235	9.3	97	3.8	84	3.3	1.1	2.4
025D	3/4"	275	10.8	129	5.1	115	4.5	2.2	4.8
025E	1"	275	10.8	129	5.1	115	4.5	2.2	4.8
030E	1"	364	14.3	129	5.1	115	4.5	2.7	5.9
030F	1 1/4"	364	14.3	129	5.1	115	4.5	2.7	5.9
030G	1 1/2"	364	14.3	129	5.1	115	4.5	2.7	5.9
035F	1 1/4"	432	17.0	170	6.7	156	6.1	5.1	11.2
035G	1 1/2"	432	17.0	170	6.7	156	6.1	5.1	11.2
040G	1 1/2"	524	20.6	170	6.7	156	6.1	5.7	12.5
040H	2"	524	20.6	170	6.7	156	6.1	5.7	12.5
045H	2"	524	20.6	170	6.7	156	6.1	5.7	12.5
050I	2 1/2"	641	25.3	205	8.1	181	7.1	11.1	24.4
050J	3"	641	25.3	205	8.1	181	7.1	11.1	24.4
055I	2 1/2"	832	32.8	205	8.1	181	7.1	13.9	30.6
055J	3"	832	32.8	205	8.1	181	7.1	13.9	30.6
060K	G 4	847	33.3	420	16.5	282	11.1	44.5	98.1
150ND	DN80	1000	39.4	370	14.6	285	11.2	60	132
200ND	DN80	1220	48.0	370	14.6	285	11.2	70	154
250OD	DN100	1345	53.0	500	19.7	405	15.9	145	320
300OD	DN100	1345	53.0	500	19.7	405	15.9	145	320
350PD	DN150	1445	56.9	580	22.8	460	18.1	190	420
400QD	DN200	1710	67.3	750	29.5	640	25.1	375	827
450RD	DN250	1840	72.4	862	33.9	715	28.1	495	1090
500SD	DN300	1930	76.0	1000	39.4	840	33.1	600	1323

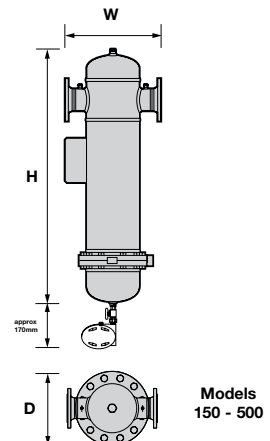
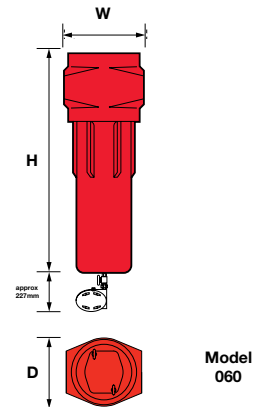
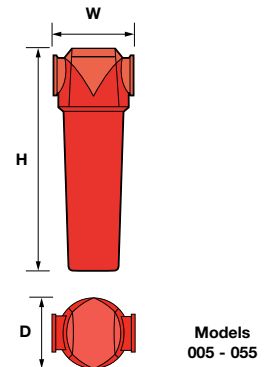

OIL-X EVOLUTION

Oil vapour removal filters - Grades OVR/ACS/AC

Filtration Performance

Filtration Grade	Filter Type	Particle removal (inc water & oil aerosols)	Max Remaining Oil Content at 21°C (70°F)	Filtration Efficiency	Test Methods Used	ISO12500-1 Inlet Challenge Concentration	Initial Dry Differential Pressure	Initial Saturated Differential Pressure	Absorbent Life	Precede with Filtration Grade
OVR	Oil Vapour Removal	N/A	0.003 mg/m ³ 0.003 ppm(w)	N/A	ISO8573-5	N/A	<350 mbar (5psi)	N/A	6000 hrs*	AA
ACS	Oil Vapour Removal	N/A	0.003 mg/m ³ 0.003 ppm(w)	N/A	ISO8573-5	N/A	<200 mbar (3psi)	N/A	When oil vapour or odour is detected	AA
AC	Oil Vapour Removal	N/A	0.003 mg/m ³ 0.003 ppm(w)	N/A	ISO8573-5	N/A	<775 mbar (11psi)	N/A	When oil vapour or odour is detected	AO

* When corrected to match system conditions

Product Selection - Grade OVR Plant scale and point of use oil vapour removal

	Model	Pipe Size	Flow Rates				Replacement Element Kit	No. Req'd
			L/s	m ³ /min	m ³ /hr	cfm		
Modular Aluminum range	OVR100E □ XX	G 1	80	4.8	288	170	100OVR	1
	OVR150H □ XX	G 2	160	9.6	576	339	100OVR	2
	OVR200H □ XX	G 2	330	19.8	1188	699	100OVR	4
	OVR250J □ XX	G 3	620	37.2	2232	1314	100OVR	6
	2 x OVR250J	G 3	1240	74.5	4465	2628		
	3 x OVR250J	G 3	1860	111.8	6696	3941		
	4 x OVR250J	G 3	2480	149.1	8928	5255		
	5 x OVR250J	G 3	3100	186.4	11160	6569		

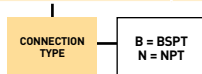

Correction Factors Temperature (CFT)

Oil Lubricated Compressors

CFT Inlet Air Temperature		Correction Factor
°C	°F	
20	68	1.00
25	77	1.53
30	86	2.33
35	95	3.55
40	104	5.47
45	113	8.55
50	122	13.23

Oil-free Compressors

CFT Inlet Air Temperature		Correction Factor
°C	°F	
20	68	1.00
25	77	1.02
30	86	1.03
35	95	1.05
40	104	1.07
45	113	1.09
50	122	1.10

Correction Factors Pressure (CFP)

CFP Inlet Pressure		Correction Factor	CFP Inlet Pressure		Correction Factor
bar g	psi g		bar g	psi g	
3	44	2.00	10	145	1.00
4	58	1.60	11	160	1.00
5	73	1.33	12	174	1.00
6	87	1.14	13	189	1.00
7	100	1.00	14	203	1.00
8	116	1.00	15	218	1.00
9	131	1.00	16	232	1.00

Correction Factors Dewpoint (CFD)

CFD Dewpoint	°C	°F	Correction Factor
Dry	-70 to +3	-100 to +38	1.00
Wet	+3 and above	+38 and above	2.00

It is assumed inlet oil vapour concentration does not exceed 0.05mg/m³ at 21°C (70°F). For applications with higher oil vapour concentrations, please contact Parker domnick hunter for accurate sizing.

Filter Selection - Grade OVR

To correctly select an OVR oil vapour removal filter, the flow rate of the OVR must be adjusted for the minimum operating pressure, maximum operational temperature and pressure dewpoint of the system.

- Obtain the minimum operating pressure, maximum inlet temperature, maximum compressed air flow rate and dewpoint of the compressed air at the inlet of the OVR.
- Select correction factor for maximum inlet temperature from the CFT table that corresponds to compressor type (always round up e.g. for 37°C use 40°C correction factor).
- Select correction factor for minimum inlet pressure from the CFP table that corresponds to compressor type (always round down e.g. for 5.3 bar use 5 bar correction factor).
- Select correction factor for pressure dewpoint from the CFD table.
- Calculate minimum filtration capacity.
Minimum filtration Capacity =
Compressed Air Flow x CFT x CFP x CFD
- Using the minimum filtration capacity, select an OVR model from the flow rate tables above (OVR selected must have a flow rate equal to or greater than the minimum filtration capacity).

If the minimum filtration capacity exceeds the maximum values of the models shown within the tables, please contact Parker domnick hunter for advice regarding larger multi-banked units.

Product Selection - Grade ACS Point of use oil vapour removal

Stated flows are for operation at 7 bar g (100 psi g) with reference to 20°C, 1 bar a, 0% relative water vapour pressure. For flows at other pressures apply the correction factors shown.

	Model	Pipe Size	L/S	Flow Rates			Replacement Element kit	No.
				m³/min	m³/hr	cfm		
Cast Aluminum Filters	ACS 005A □ MX	1/4"	6	0.4	22	13	005 ACS	1
	ACS 005B □ MX	3/8"	6	0.4	22	13	005 ACS	1
	ACS 005C □ MX	1/2"	6	0.4	22	13	005 ACS	1
	ACS 010A □ MX	1/4"	10	0.6	36	21	010 ACS	1
	ACS 010B □ MX	3/8"	10	0.6	36	21	010 ACS	1
	ACS 010C □ MX	1/2"	10	0.6	36	21	010 ACS	1
	ACS 015B □ MX	3/8"	20	1.2	72	42	015 ACS	1
	ACS 015C □ MX	1/2"	20	1.2	72	42	015 ACS	1
	ACS 020C □ MX	1/2"	30	1.8	108	64	020 ACS	1
	ACS 020D □ MX	3/4"	30	1.8	108	64	020 ACS	1
	ACS 020E □ MX	1"	30	1.8	108	64	020 ACS	1
	ACS 025D □ MX	3/4"	60	3.6	216	127	025 ACS	1
	ACS 025E □ MX	1"	60	3.6	216	127	025 ACS	1
	ACS 030E □ MX	1"	110	6.6	396	233	030 ACS	1
	ACS 030F □ MX	1 1/4"	110	6.6	396	233	030 ACS	1
	ACS 030G □ MX	1 1/2"	110	6.6	396	233	030 ACS	1
	ACS 035F □ MX	1 1/4"	160	9.6	576	339	035 ACS	1
	ACS 035G □ MX	1 1/2"	160	9.6	576	339	035 ACS	1
	ACS 040G □ MX	1 1/2"	220	13.2	792	466	040 ACS	1
	ACS 040H □ MX	2"	220	13.2	792	466	040 ACS	1
	ACS 045H □ MX	2"	330	19.8	1188	699	045 ACS	1
	ACS 050I □ MX	2 1/2"	430	25.9	1548	911	050 ACS	1
	ACS 050J □ MX	3"	430	25.9	1548	911	050 ACS	1
ACS 055I □ MX	2 1/2"	620	37.3	2232	1314	055 ACS	1	
ACS 055J □ MX	3"	620	37.3	2232	1314	055 ACS	1	
ACS 060K □ MX	G 4	1000	60	3600	2119	060 ACS	3	
Carbon Steel Filters	ACS 150ND MX	DN80	430	25.9	1548	911	150 ACS	1
	ACS 200ND MX	DN80	620	37.3	2232	1314	200 ACS	1
	ACS 250OD MX	DN100	1000	60	3600	2119	060 ACS	3
	ACS 300OD MX	DN100	1300	78	4680	2755	060 ACS	4
	ACS 350PD MX	DN150	1950	117	7020	4132	060 ACS	6
	ACS 400QD MX	DN200	3250	195	11700	6887	060 ACS	10
	ACS 450RD MX	DN250	5200	313	18720	11019	060 ACS	16
ACS 500SD MX	DN300	7800	469	28080	16528	060 ACS	24	

Note: Connection sizes, (005 - 055) BSPT/NPT option available, G = BSPP and DN = flanged connection.

Product Selection - Grade AC point of use oil vapour removal

	Model	Flow Rates				Replacement Elements	
		Pipe Size BSPT	L/s	m³/min	m³/hr	cfm	
Cast Aluminum Filters	AC010A □ FI	1/4"	6	0.4	22	13	010AA 010AC
	AC010B □ FI	3/8"	6	0.4	22	13	010AA 010AC
	AC010C □ FI	1/2"	6	0.4	22	13	010AA 010AC
	AC015B □ FI	3/8"	13	0.8	46	27	015AA 015AC
	AC015C □ FI	1/2"	13	0.8	46	27	015AA 015AC
	AC020C □ FI	1/2"	25	1.5	90	53	020AA 020AC
	AC020D □ FI	3/4"	25	1.5	90	53	020AA 020AC
	AC020E □ FI	1"	25	1.5	90	53	020AA 020AC
	AC025D □ FI	3/4"	40	2.4	143	84	025AA 025DAC
	AC025E □ FI	1"	65	3.9	231	136	025AA 025EAC
	AC030E □ FI	1"	85	5.1	305	180	030AA 030AC
	AC030F □ FI	1 1/4"	85	5.1	305	180	030AA 030AC
	AC030G □ FI	1 1/2"	85	5.1	305	180	030AA 030AC

To correctly select a filter model, the flow rate of the filter must be adjusted for the minimum operating pressure of the system

- Obtain the minimum operating pressure and maximum compressed air flow rate at the inlet of the filter.
- Select the correction factor for minimum operating pressure from the CFP table (always round down e.g. for 5.3 bar, use 5 bar correction factor)
- Calculate the minimum filtration capacity Minimum Filtration Capacity = Compressed Air Flow Rate x CFP
- Using the minimum filtration capacity, select a filter model from the flow rate tables above (filter selected must have a flow rate equal to or greater than the minimum filtration capacity)

Correction Factors

Grades ACS and AC only

Line Pressure		Correction Factor pressure (CFP)
bar g	psi g	
1	15	2.65
2	29	1.87
3	44	1.53
4	58	1.32
5	73	1.18
6	87	1.08
7	100	1.00
8	116	0.94
9	131	0.88
10	145	0.84
11	160	0.80
12	174	0.76
13	189	0.73
14	203	0.71
15	218	0.68
16	232	0.66
All ACS models are fitted with a manual drain. AC models are supplied with a float drain as standard. For Pressures of 16 to 20 bar g (232 to 290 psi g) a manual drain must be used.		
17	248	0.64
18	263	0.62
19	277	0.61
20	290	0.59

Filter Coding Examples

ACS 005 - 060

GRADE	MODEL	PIPE SIZE	CONNECTION TYPE	DRAIN OPTION	BULK OIL INDICATOR
ACS	3 digit code shown above	Letter denotes pipe size	B = BSPT N = NPT	M = Manual	X = None
ACS	010	A	B	M	X

ACS 150 - 500

GRADE	MODEL	FLANGE SIZE	CONNECTION TYPE	DRAIN OPTION	BULK OIL INDICATOR
ACS	3 digit code shown above	Letter denotes flange connection	D = DN	M = Manual	X = None
ACS	150	N	D	M	X

AC 010 - 030

GRADE	MODEL	PIPE SIZE	CONNECTION TYPE	DRAIN OPTION	BULK OIL INDICATOR
AC	3 digit code shown above	Letter denotes pipe size	B = BSPT N = NPT	F = Float M = Manual	I = Bulk Oil Indicator
AC	010	A	B	F	I

AC models are supplied with a float drain as standard. For Pressures of 16 to 20 bar g (232 to 290 psi g) a manual drain must be used.

OIL-X EVOLUTION

Oil vapour removal (continued)

Technical Data

Filter Grade	Filter Models	Min Operating Pressure		Max Operating Pressure		Min Operating Temp		Max Operating Temp	
		bar g	psi g	bar g	psi g	°C	°F	°C	°F
OVR	100E □ XX - 250J □ XX	1	15	16	232	2	35	50	122
ACS	005A □ MX - 060K □ MX	1	15	20	290	2	35	50	122
ACS	150NDMX - 500SDMX	1	15	16	232	2	35	50	122
AC	010A □ FI - 030G □ FI	1	15	16	232	2	35	30	86

Weights and Dimensions

Model	Pipe Size	Height (H)		Width (W)		Depth (D)		Weight	
		mm	ins	mm	ins	mm	ins	kg	lbs
OVR100E	G 1	670	26.3	352	13.8	250	9.8	25	55
OVR150H	G 2	797	31.3	504	19.9	300	11.8	42	93
OVR200H	G 2	797	31.3	829	32.6	300	11.8	74	163
OVR250J	G 3	816	32.1	1194	47.0	300	11.8	107	235
ACS 005A □ MX	1/4"	154	6.1	76	3.0	64	2.5	0.5	1.1
ACS 005B □ MX	3/8"	154	6.1	76	3.0	64	2.5	0.5	1.1
ACS 005C □ MX	1/2"	154	6.1	76	3.0	64	2.5	0.5	1.1
ACS 010A □ MX	1/4"	181	7.2	76	3.0	64	2.5	0.6	1.3
ACS 010B □ MX	3/8"	181	7.2	76	3.0	64	2.5	0.6	1.3
ACS 010C □ MX	1/2"	181	7.2	76	3.0	64	2.5	0.6	1.3
ACS 015B □ MX	3/8"	235	9.3	97	3.8	84	3.3	1.1	2.4
ACS 015C □ MX	1/2"	235	9.3	97	3.8	84	3.3	1.1	2.4
ACS 020C □ MX	1/2"	235	9.3	97	3.8	84	3.3	1.1	2.4
ACS 020D □ MX	3/4"	235	9.3	97	3.8	84	3.3	1.1	2.4
ACS 020E □ MX	1"	235	9.3	97	3.8	84	3.3	1.1	2.4
ACS 025D □ MX	3/4"	275	10.8	129	5.1	115	4.5	2.2	4.8
ACS 025E □ MX	1"	275	10.8	129	5.1	115	4.5	2.2	4.8
ACS 030E □ MX	1"	364	14.3	129	5.1	115	4.5	2.7	5.9
ACS 030F □ MX	1 1/4"	364	14.3	129	5.1	115	4.5	2.7	5.9
ACS 030G □ MX	1 1/2"	364	14.3	129	5.1	115	4.5	2.7	5.9
ACS 035F □ MX	1 1/4"	432	17.0	170	6.7	156	6.1	5.1	11.2
ACS 035G □ MX	1 1/2"	432	17.0	170	6.7	156	6.1	5.1	11.2
ACS 040G □ MX	1 1/2"	524	20.6	170	6.7	156	6.1	5.7	12.5
ACS 040H □ MX	2"	524	20.6	170	6.7	156	6.1	5.7	12.5
ACS 045H □ MX	2"	524	20.6	170	6.7	156	6.1	5.7	12.5
ACS 050I □ MX	2 1/2"	641	25.3	205	8.1	181	7.1	11.1	24.4
ACS 050J □ MX	3"	641	25.3	205	8.1	181	7.1	11.1	24.4
ACS 055I □ MX	2 1/2"	832	32.8	205	8.1	181	7.1	13.9	30.6
ACS 055J □ MX	3"	832	32.8	205	8.1	181	7.1	13.9	30.6
ACS 060KMX	G 4	847	33.3	420	16.5	282	11.1	44.5	98
ACS 150ND MX	DN80	1000	39.4	370	14.6	285	11.2	60	132
ACS 200ND MX	DN80	1220	48.0	370	14.6	285	11.2	70	154
ACS 250OD MX	DN100	1345	53.0	500	19.7	405	15.9	145	320
ACS 300OD MX	DN100	1345	53.0	500	19.7	405	15.9	145	320
ACS 350PD MX	DN150	1445	56.9	580	22.8	460	18.1	190	420
ACS 400QD MX	DN200	1710	67.3	750	29.5	640	25.1	375	827
ACS 450RD MX	DN250	1840	72.4	862	33.9	715	28.1	495	1090
ACS 500SD MX	DN300	1930	76.0	1000	39.4	840	33.1	600	1323
AC010A □ FI	1/4"	311	12.3	76	3.0	65	2.6	0.8	1.8
AC010B □ FI	3/8"	311	12.3	76	3.0	65	2.6	0.8	1.8
AC010C □ FI	1/2"	311	12.3	76	3.0	65	2.6	0.8	1.8
AC015B □ FI	3/8"	474	18.7	97	3.8	84	3.3	1.6	3.5
AC015C □ FI	1/2"	474	18.7	97	3.8	84	3.3	1.6	3.5
AC020C □ FI	1/2"	474	18.7	97	3.8	84	3.3	1.45	3.2
AC020D □ FI	3/4"	474	18.7	97	3.8	84	3.3	1.45	3.2
AC020E □ FI	1"	474	18.7	97	3.8	84	3.3	1.45	3.2
AC025D □ FI	3/4"	554	21.8	129	5.1	115	4.5	3.5	7.8
AC025E □ FI	1"	554	21.8	129	5.1	115	4.5	3.4	7.6
AC030E □ FI	1"	733	28.9	129	5.1	115	4.5	4.1	9.0
AC030F □ FI	1 1/4"	733	28.9	129	5.1	115	4.5	4.1	9.0
AC030G □ FI	1 1/2"	733	28.9	129	5.1	115	4.5	4.1	9.0

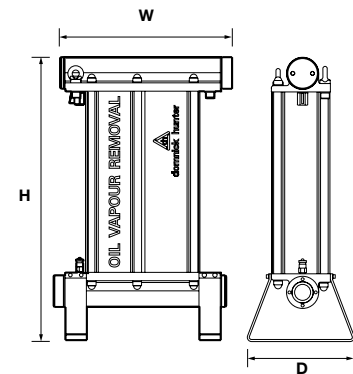

OVR 100 - 250

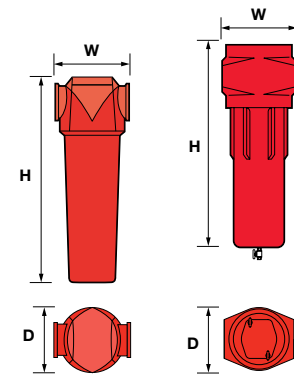

ACS 005-055

ACS 060

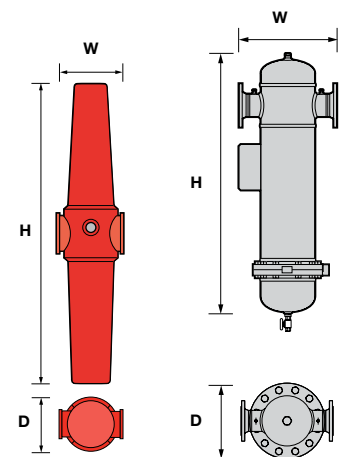

AC 010 - 030

ACS 150 - 500

OIL-X EVOLUTION

Accessories



Incident monitor

Used to indicate premature high differential pressure. Indicator can be retrofitted to existing housings without depressurising the system.

Filter model	
015 - 055	DPM
060	DPM - 060
150 - 500	DPM - FAB



Filter fixing kits

Fixing clamp allows quick and simple connection of multiple filter housings.

Filter model	
005 - 010	FXKE1
015 - 020	FXKE2
025 - 030	FXKE3
035 - 045	FXKE4
050 - 055	FXKE5



Filter mounting brackets

Mounting brackets provide additional support to filters installed in flexible piping systems or OEM equipment.

Filter model	
005 - 010	MBKE1
015 - 020	MBKE2
025 - 030	MBKE3
035 - 045	MBKE4
050 - 055	MBKE5

Other filtration products



Parfit Compressed Air Filter Elements



Compressed Air Filters up to 50 bar g (740 psi g)



Compressed Air Filter up to 350 bar g (5000 psi g)

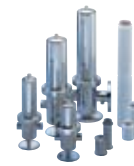

Sterile Air Filters



Stainless Steel Compressed Air Filters



Multi-ported Compressed Air Filters



Point of use Air Tool Protector



Breathing Air Purifiers



Medical Vacuum Filters



Vacuum Pump Inlet and Exhaust Filters



Carbon Dioxide Purifiers



Oil / Water Separators

Aftermarket

Compressed air equipment users demand much more than the supply of high quality products in order to maintain a competitive edge.

Modern production technology is increasingly demanding the provision of a higher purity and more reliable compressed air supply. Products and solutions that are manufactured by Parker domnick hunter are designed to provide air quality that meets with and often exceeds international standards.

As well as the requirement for air purity and reliability, there are additional factors to consider when choosing the right service provider for your compressed air and gas purification system. For example, knowledge of the many regulations regarding the management of industrial waste, energy efficiency improvement programs and consideration of any environmental impact. It is anticipated that future legislations will demand further in-depth technical and knowledge-based support from service providers.

Our commitment to industry does not stop with the supply of high quality products. We are also committed to ensuring that our equipment provides high performance by providing a trouble-free service from a bespoke maintenance and verification package – all tailored to your own specific requirements.

We offer a wide range of valuable services that will impact positively on your drive towards improved production efficiency and product quality with reduced production rejections and operational costs.

From initial selection to installation, commissioning, preventative maintenance and specialised services, Parker domnick hunter is redefining customer service.



Filter Elements and Consumable Parts	Maintenance, Repair and Overhaul	Customer Support	Specialised Services
<ul style="list-style-type: none"> Genuine Replacement filter elements Preventative Maintenance Kits Repair Kits Installation Kits Upgrade Kits 	<ul style="list-style-type: none"> Installation and Commissioning Maintenance and Repair Updates and Upgrades Service Contracts Parts Service Warranty 	<ul style="list-style-type: none"> Business Development Technical Support Group Training Technical Publications 	<ul style="list-style-type: none"> Air Quality Testing Dewpoint Measurement Leak Detection Particle Counting Micro-biological Testing

Parker's Motion & Control Technologies

Parker is guided by a relentless drive to help our customers become more productive and achieve higher levels of profitability by engineering the best systems for their requirements. It means looking at customer applications from many angles to find new ways to create value. Whatever the motion and control technology need, Parker has the experience, breadth of product and global reach to consistently deliver. No company knows more about motion and control technology than Parker. For further info call 00800 27 27 5374.



AEROSPACE

Key Markets

- Aircraft engines
- Business & general aviation
- Commercial transports
- Land-based weapons systems
- Military aircraft
- Missiles & launch vehicles
- Regional transports
- Unmanned aerial vehicles

Key Products

- Flight control systems & components
- Fluid conveyance systems
- Fluid metering delivery & atomization devices
- Fuel systems & components
- Hydraulic systems & components
- Inert nitrogen generating systems
- Pneumatic systems & components
- Wheels & brakes



CLIMATE CONTROL

Key Markets

- Agriculture
- Air conditioning
- Food, beverage & dairy
- Life sciences & medical
- Precision cooling
- Processing
- Transportation

Key Products

- CO2 controls
- Electronic controllers
- Filter driers
- Hand shut-off valves
- Hose & fittings
- Pressure regulating valves
- Refrigerant distributors
- Safety relief valves
- Solenoid valves
- Thermostatic expansion valves



ELECTROMECHANICAL

Key Markets

- Aerospace
- Factory automation
- Food & beverage
- Life science & medical
- Machine tools
- Packaging machinery
- Paper machinery
- Plastics machinery & converting
- Primary metals
- Semiconductor & electronics
- Textile
- Wire & cable

Key Products

- AC/DC drives & systems
- Electric actuators
- Controllers
- Gantry robots
- Gearheads
- Human machine interfaces
- Industrial PCs
- Inverters
- Linear motors, slides and stages
- Precision stages
- Stepper motors
- Servo motors, drives & controls
- Structural extrusions



FILTRATION

Key Markets

- Food & beverage
- Industrial machinery
- Life sciences
- Marine
- Mobile equipment
- Oil & gas
- Power generation
- Process
- Transportation

Key Products

- Analytical gas generators
- Compressed air & gas filters
- Condition monitoring
- Engine air, fuel & oil filtration & systems
- Hydraulic, lubrication & coolant filters
- Process, chemical, water & microfiltration filters
- Nitrogen, hydrogen & zero air generators



FLUID & GAS HANDLING

Key Markets

- Aerospace
- Agriculture
- Bulk chemical handling
- Construction machinery
- Food & beverage
- Fuel & gas delivery
- Industrial machinery
- Mobile
- Oil & gas
- Transportation
- Welding

Key Products

- Brass fittings & valves
- Diagnostic equipment
- Fluid conveyance systems
- Industrial hose
- PTFE & PFA hose, tubing & plastic fittings
- Rubber & thermoplastic hose & couplings
- Tube fittings & adapters
- Quick disconnects



HYDRAULICS

Key Markets

- Aerospace
- Aerial lift
- Agriculture
- Construction machinery
- Forestry
- Industrial machinery
- Mining
- Oil & gas
- Power generation & energy
- Truck hydraulics

Key Products

- Diagnostic equipment
- Hydraulic cylinders & accumulators
- Hydraulic motors & pumps
- Hydraulic systems
- Hydraulic valves & controls
- Power take-offs
- Rubber & thermoplastic hose & couplings
- Tube fittings & adapters
- Quick disconnects



PNEUMATICS

Key Markets

- Aerospace
- Conveyor & material handling
- Factory automation
- Food & beverage
- Life science & medical
- Machine tools
- Packaging machinery
- Transportation & automotive

Key Products

- Air preparation
- Compact cylinders
- Field bus valve systems
- Grippers
- Guided cylinders
- Manifolds
- Miniature fluidics
- Pneumatic accessories
- Pneumatic actuators & grippers
- Pneumatic valves and controls
- Rodless cylinders
- Rotary actuators
- Tie rod cylinders
- Vacuum generators, cups & sensors



PROCESS CONTROL

Key Markets

- Chemical & refining
- Food, beverage & dairy
- Medical & dental
- Microelectronics
- Oil & gas
- Power generation

Key Products

- Analytical sample conditioning products & systems
- Fluoropolymer chemical delivery fittings, valves & pumps
- High purity gas delivery fittings, valves & regulators
- Instrumentation fittings, valves & regulators
- Medium pressure fittings & valves
- Process control manifolds



SEALING & SHIELDING

Key Markets

- Aerospace
- Chemical processing
- Consumer
- Energy, oil & gas
- Fluid power
- General industrial
- Information technology
- Life sciences
- Military
- Semiconductor
- Telecommunications
- Transportation

Key Products

- Dynamic seals
- Elastomeric o-rings
- EMI shielding
- Extruded & precision-cut, fabricated elastomeric seals
- Homogeneous & inserted elastomeric shapes
- High temperature metal seals
- Metal & plastic retained composite seals
- Thermal management



ENGINEERING YOUR SUCCESS.



Europe, Middle East, Africa

AE – United Arab Emirates, Dubai

Tel: +971 4 8127100
parker.me@parker.com

AT – Austria, Wiener Neustadt

Tel: +43 (0)2622 23501-0
parker.austria@parker.com

AT – Eastern Europe, Wiener Neustadt

Tel: +43 (0)2622 23501 900
parker.easteurope@parker.com

AZ – Azerbaijan, Baku

Tel: +994 50 2233 458
parker.azerbaijan@parker.com

BE/LU – Belgium, Nivelles

Tel: +32 (0)67 280 900
parker.belgium@parker.com

BY – Belarus, Minsk

Tel: +375 17 209 9399
parker.belarus@parker.com

CH – Switzerland, Etoy

Tel: +41 (0)21 821 87 00
parker.switzerland@parker.com

CZ – Czech Republic, Klecany

Tel: +420 284 083 111
parker.czechrepublic@parker.com

DE – Germany, Kaarst

Tel: +49 (0)2131 4016 0
parker.germany@parker.com

DK – Denmark, Ballerup

Tel: +45 43 56 04 00
parker.denmark@parker.com

ES – Spain, Madrid

Tel: +34 902 330 001
parker.spain@parker.com

FI – Finland, Vantaa

Tel: +358 (0)20 753 2500
parker.finland@parker.com

FR – France, Contamine s/Arve

Tel: +33 (0)4 50 25 80 25
parker.france@parker.com

GR – Greece, Athens

Tel: +30 210 933 6450
parker.greece@parker.com

HU – Hungary, Budapest

Tel: +36 1 220 4155
parker.hungary@parker.com

IE – Ireland, Dublin

Tel: +353 (0)1 466 6370
parker.ireland@parker.com

IT – Italy, Corsico (MI)

Tel: +39 02 45 19 21
parker.italy@parker.com

KZ – Kazakhstan, Almaty

Tel: +7 7272 505 800
parker.easteurope@parker.com

NL – The Netherlands, Oldenzaal

Tel: +31 (0)541 585 000
parker.nl@parker.com

NO – Norway, Asker

Tel: +47 66 75 34 00
parker.norway@parker.com

PL – Poland, Warsaw

Tel: +48 (0)22 573 24 00
parker.poland@parker.com

PT – Portugal, Leca da Palmeira

Tel: +351 22 999 7360
parker.portugal@parker.com

RO – Romania, Bucharest

Tel: +40 21 252 1382
parker.romania@parker.com

RU – Russia, Moscow

Tel: +7 495 645-2156
parker.russia@parker.com

SE – Sweden, Spånga

Tel: +46 (0)8 59 79 50 00
parker.sweden@parker.com

SK – Slovakia, Banská Bystrica

Tel: +421 484 162 252
parker.slovakia@parker.com

SL – Slovenia, Novo Mesto

Tel: +386 7 337 6650
parker.slovenia@parker.com

TR – Turkey, Istanbul

Tel: +90 216 4997081
parker.turkey@parker.com

UA – Ukraine, Kiev

Tel +380 44 494 2731
parker.ukraine@parker.com

UK – United Kingdom, Warwick

Tel: +44 (0)1926 317 878
parker.uk@parker.com

ZA – South Africa, Kempton Park

Tel: +27 (0)11 961 0700
parker.southafrica@parker.com

North America

CA – Canada, Milton, Ontario

Tel: +1 905 693 3000

US – USA, Cleveland

Tel: +1 216 896 3000

Asia Pacific

AU – Australia, Castle Hill

Tel: +61 (0)2-9634 7777

CN – China, Shanghai

Tel: +86 21 2899 5000

HK – Hong Kong

Tel: +852 2428 8008

IN – India, Mumbai

Tel: +91 22 6513 7081-85

JP – Japan, Tokyo

Tel: +81 (0)3 6408 3901

KR – South Korea, Seoul

Tel: +82 2 559 0400

MY – Malaysia, Shah Alam

Tel: +60 3 7849 0800

NZ – New Zealand, Mt Wellington

Tel: +64 9 574 1744

SG – Singapore

Tel: +65 6887 6300

TH – Thailand, Bangkok

Tel: +662 186 7000-99

TW – Taiwan, Taipei

Tel: +886 2 2298 8987

South America

AR – Argentina, Buenos Aires

Tel: +54 3327 44 4129

BR – Brazil, Sao Jose dos Campos

Tel: +55 800 727 5374

CL – Chile, Santiago

Tel: +56 2 623 1216

MX – Mexico, Apodaca

Tel: +52 81 8156 6000

European Product Information Centre

Free phone: 00 800 27 27 5374

(from AT, BE, CH, CZ, DE, DK, EE, ES, FI, FR, IE, IL, IS, IT, LU, MT, NL, NO, PL, PT, RU, SE, SK, UK, ZA)