



The adaptable valve terminal VTUX



Highlights

- High flow rates of up to 730 l/min
- Lightweight, made of high-performance polymer
- Extremely flexible to use, for communication and machine concepts
- Highly modular
- It combines all the benefits of CPV, MPA and VTUG in one platform
- Open for future developments

The VTUX sets new standards in terms of materials, modularity and communication. The successor to the established CPV, MPA-L/S and VTUG ranges impresses with its high flow rate. And with the communication system AP-I and AP-A, it is the perfect platform for digitised production!

Flexible

Thanks to internal communication, the modules can be arranged as required. This provides maximum freedom when designing the valve terminal.

Machine concepts are a priority

The VTUX is clearly geared to the control architecture of the machine – it always fits, whether for multipin or bus technology!

Superb communication

AP communication technology ensures the connections are really simple, even over long distances, as if all system participants were in the same place.

Tubing connections? Easy to configure!

Even the fittings can be configured to the required tubing diameter, saving space and ensuring optimised air flows. You can also define as many pressure zones as you like.

Can be used virtually anywhere

Not only can the VTUX be used with short compressed air lines, it also has a lightweight design, making it ideal for use on front end units, such as a gantry or robot arm.



Additional information:

Product page

> www.festo.com/catalogue/vtux

Online Shop

> www.festo.com/vtux



The VTUX integrated in the AP communication network

AP ensures flawless and future-proof communication between the components of an automation system:

- Faster data rates up to 200 MBaud
- Faster cycle times up to 250 µs
- Process data processing 2 kByte input / 2 kByte output
- Real-time communication to the valve terminal

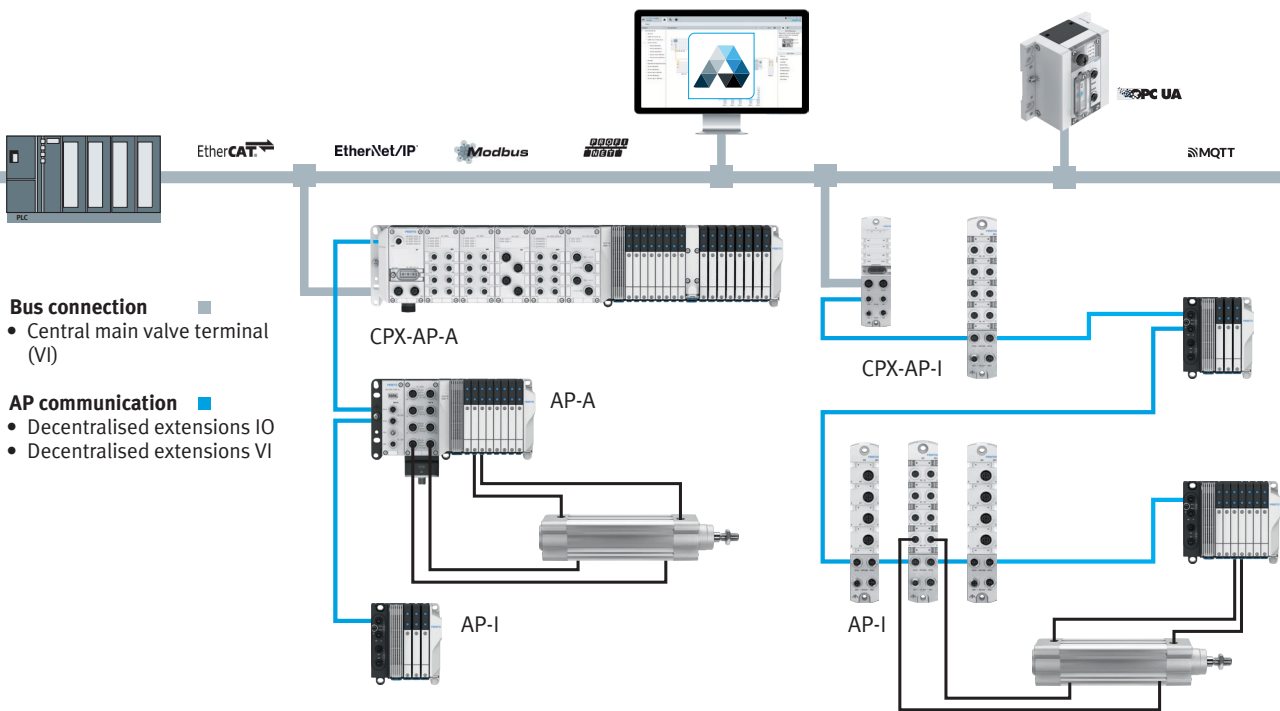

More flexible than ever

The valve terminal can be designed as required, both in terms of how the different-sized valve sub-bases and functionalities are arranged, and in terms of splitting the functions into any number of sub-units.



Compact and lightweight

Thanks to the innovative design and construction, the VTUX offers all the advantages for decentralised machine concepts. It is lightweight, has a small footprint, offers excellent flow rates and is attractively priced.